

# **SERVICE MANUAL**

## **PROJECT TWELVE**

### **MONO POWER AMPLIFIER**

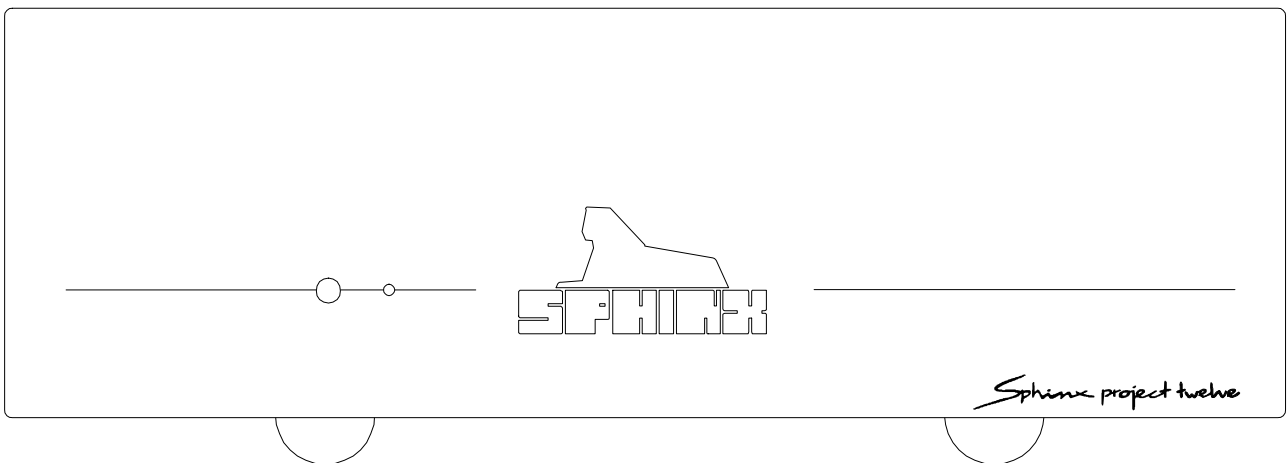

## Contents

<b>1. UNPACKING .....</b>	<b>3</b>
<b>2. SPHINX WARRANTY CARD .....</b>	<b>3</b>
<b>3. CONTACTING THE MANUFACTURER .....</b>	<b>3</b>
<b>4. THE POWER AMP AT A GLANCE.....</b>	<b>4</b>
Front panel.....	4
Rear panel .....	5
<b>5. TECHNICAL SPECIFICATIONS .....</b>	<b>6</b>
<b>6. GENERAL CHECKLIST .....</b>	<b>7</b>
Optical connections .....	7
Switching the amp on.....	7
Protection mode.....	7
Cables.....	7
<b>7. USING THE AMP WITHOUT PROTECTION CIRCUIT .....</b>	<b>8</b>
Removing the protection circuit board .....	8
Repositioning the protection circuit board.....	8
<b>8. ADJUSTMENT PROCEDURES .....</b>	<b>9</b>
Bias .....	9
Offset .....	10
Common mode .....	10
<b>9. PROBLEMS AND SOLUTIONS.....</b>	<b>11</b>
<b>10. DIAGRAMS AND PARTS LISTS .....</b>	<b>12</b>
Connection diagram for testing the project 12 .....	13
Schematic layout of project 12 with securityprint.....	14
Schematic layout of all relevant parts .....	15
Project 12 amplifier diagram .....	16
Project 12 protection diagram .....	17
PCB drawings of Project 12 .....	18
Partlist amplifier .....	19
Partlist protection .....	22

## The Sphinx Project Twelve design

The Sphinx Project Twelve was designed for the ever-increasing group of quality-conscious audiophiles.

We are very proud of the tradition connected with the SPHINX name, especially concerning audio quality perfection.

This service manual will help you to optimally service and repair the Sphinx Project Twelve Mono Power Amplifier.

The design is based on the long experience of the Sphinx design team with ultra-wide bandwidth power FETs.

These have a unique and extremely wide power bandwidth exceeding 1.5 MHz, a very high slew rate of over 100 V/ $\mu$ s and an unequalled perfect phase linearity over the complete frequency bandwidth.

Six of these 100 W FETs are used to obtain maximum reliability.

The extremely low output impedance results in a damping factor of over 600!

Together with the very 'heavy' power supply and its large energy buffer of 26,920  $\mu$ F, this results in an effortless sound with a very large dynamic range and an unsurpassed transient response.

Much attention has also been paid to the physical layout, the positioning of components and the internal grounding. This results in an equivalent input noise value of  $<1 \mu$ V ( $<-120$  dBV): remarkable for a pre-amp, but really astounding for a big power amp with two transformers.

All of this means that the Project Twelve can work with all kind of loads from every loudspeaker: even the most difficult ones like electrostatic and magnetostatic...

To obtain the maximum quality from this power amp it is necessary to use it with top quality audio components preferably with other Sphinx components.

**Please also refer to the User Manual of the Project Twelve for information about functions not described in this manual. It is important to familiarise yourself with the special functions, operation and possibilities of the Sphinx Project Twelve.**

## 1. UNPACKING

Before leaving the factory every Project Twelve is subjected to stringent and extensive technical and exterior quality inspections. This ensures the user many years of high quality audio from a perfect-looking product.

We recommend owners to ship the Project Twelve in its original carton.

After unpacking the Project Twelve we therefore recommend you carefully check it for any transport damage.

If you find any damage and the product has not been shipped in the original carton the ensuing repair costs will not be covered by the warranty.

## 2. SPHINX WARRANTY CARD

To be entitled to any warranty repairs the owner must have send the filled out warranty card to Sphinx or a distributor where it has been registered. Other regulations may apply in your specific country: when in doubt, please consult the proper authorities.

## 3. CONTACTING THE MANUFACTURER

In case of any problem not covered in this manual or if you have other questions you may contact the **Sphinx International Service Department** in The Netherlands (local time: GMT +1h) during office hours at the following numbers:

Telephone	(+31) 35 602 0302
Fax	(+31) 35 602 2806
E-mail	audionl@euronet.nl

It is always very helpful and efficient if you have all relevant information about the specific product and the problem ready.

## 4. THE POWER AMP AT A GLANCE

### Front panel

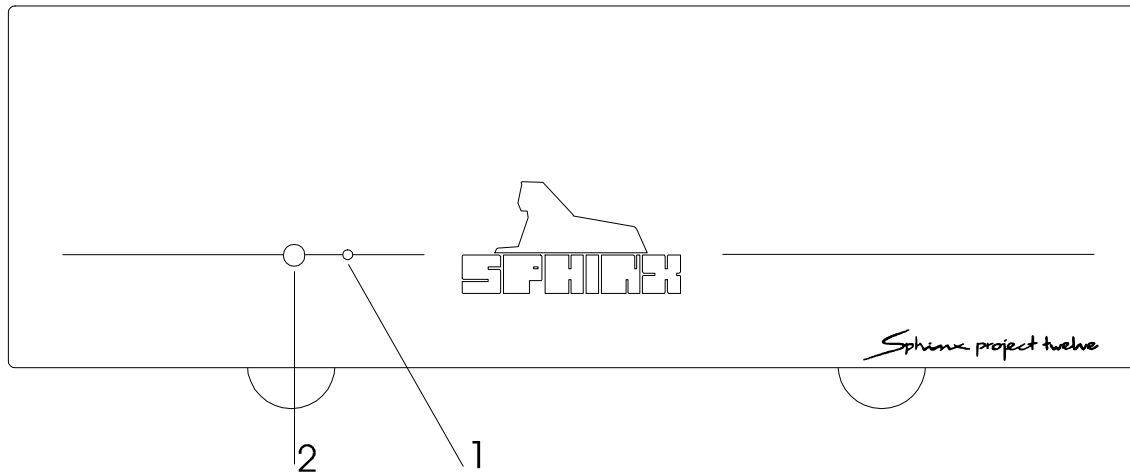

1. **LED:** Indicates the selected function:  
stand-by      red  
on              green  
protection    blinking red.
2. **STANDBY:** To switch the component on and off.

## Rear panel

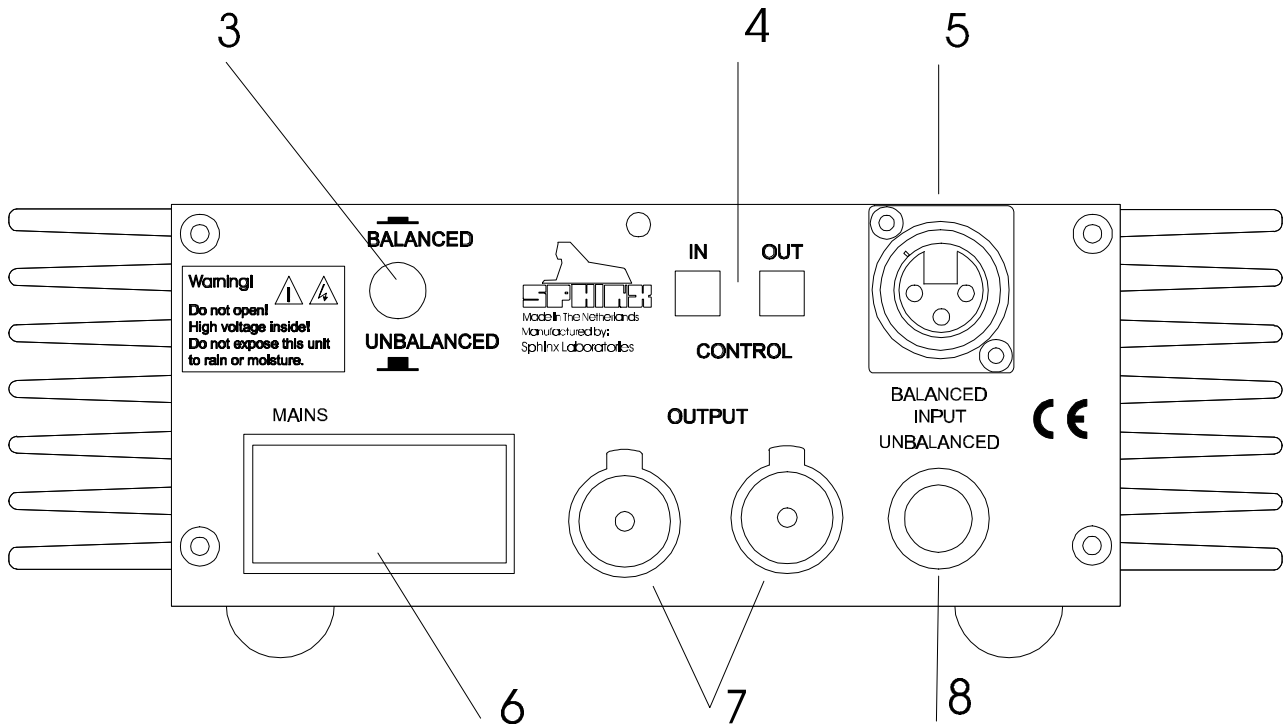

3. **BALANCED/UNBALANCED:** With this switch you may select the balanced input (5.) or the unbalanced input (8).
4. **CONTROL IN:** To connect the optical cable from another Sphinx component like a pre-amp.  
**CONTROL OUT:** To connect the optical cable that goes to another Sphinx component.
5. **BALANCED INPUT:** To connect the balanced XLR cable from the pre-amp output.
6. **MAINS:** This is the combined mains master switch (0/1) and input.  
**MAINS:** To connect the power amp to a mains outlet (230 - 240 VAC).
7. **OUTPUT:** To connect the cable from the loudspeaker:  
red +  
white -
8. **UNBALANCED INPUT:** To connect the unbalanced cinch cable from the pre-amp output.  
**Manufacturer's label:** Here you'll find important data on this component, such as serial number and mains voltage to be used.

## 5. TECHNICAL SPECIFICATIONS

Bandwidth	0 - 1.5 MHz (+0/-3 dB) 0 - 203,000 Hz after RF input filter
Phase response error	<1° (0 - 20,000 Hz)
Gain (balanced)	29.5 dB max. (x 29.9)
(unbalanced)	29.5 dB max. (x 29.9)
Minimum Power Output (1 - 20,000 Hz, 1 W = 0 dBW)	>151 W into 8 ohm (21.8 dBW), THD <0.01% >246 W into 4 ohm (23.9 dBW), THD <0.01% >340 W into 2 ohm (25.3 dBW), THD <0.01%
Output voltage / current, max.	36 V / 16 A
THD+N (IHF-A)	<0.006% (100 W into 8 ohm, 1 - 20,000 Hz)
IMD	<0.010% ( 70 W into 8 ohm)
S/N ratio (IHF-A)	>120 dB
Slew rate	>20 V/μs
Common Mode Rejection Ratio	>30dB @ 100 Hz
Damping factor	>645 @ 10 Hz >629 @ 100 Hz >595 @ 1 kHz >155 @ 10 kHz
Input level, nominal	XLR balanced / cinch WBT unbalanced 1.25 V (1.9 dBV) / 1.25 V (1.9 dBV)
impedance	600 ohm / 20 kohm
Supply capacitance	26,920 μF total
Power consumption	600 W max. (5 W standby)
Power transformer, primary	230 VAC / 115 VAC
secondary	45 VAC / 3,33 A (2x)
Temperature protection	70 °C / 158 F
Maximum DC-offset	+350 mV and -350 mV
Short circuit protection	Measured at source resistor R31
Dimensions (h x w x d)	68 x 250 x 340 mm
Weight	6,5 kg

This unit conforms to the EMC interference regulations issued by the EU and to the CE standards.  
This unit complies with safety regulation VDE 0860 and therefore with international safety regulation IEC 65.

Technical specifications may be changed by SPHINX without prior notice if technical developments make this necessary.

## 6. GENERAL CHECKLIST

Before you test or service the Project Twelve please check the following items. They will give information about the current status of the amplifier.

*Note:* The Project Twelve will become warm, so correct placement is critical. Do *not* position it on top of or close to other heat-radiating equipment (such as other power amps) or in direct sunlight.

**Please ensure unrestricted ventilation around the component.**

### Optical connections

The optical CONTROL IN (4.) is light-sensitive. A strong light source might therefore activate the CONTROL function and switch the Project Twelve to Standby.

While this mode has priority the amplifier can not be activated with the Standby switch at the front panel.

Before you start connecting equipment it is always wise to check whether all the mains cables of all components are disconnected from the mains outlets!

This will prevent any damage to the loudspeakers and amplifiers caused by incorrect wiring or settings.

Connect the mains cable after you have connected all other components in the system and have double-checked all connections.

If you use more than one Project Twelve connect them all to the same mains outlet and phase.

### Switching the amp on

Before you switch the power amp on you should always first:

- connect a pre-amp
- connect the pre-amp's Control Out to the power amp's Control In
- or place the dummy plug in the Control IN connector of the power amp.

After switching the amplifier ON the red LED (1.) will first blink slowly (1x per second) and then will light continuously.

The amp is now in Standby mode.

Pressing the Standby-button (2.) will activate the amplifier and the LED turns to green.

### Protection mode

If - after switching on - the red LED (1.) blinks rapidly (2x per second) this indicates that the protection mode is active.

This may be caused by one of the following problems:

1. The operational temperature exceeds 70 °C.
2. The output DC-offset exceeds +/- 350 mV.
3. The output is shorted (current-limiter active)

### Warning!

The output Short-circuit protection will be activated at output currents of over 27A. At lower output currents (AC or DC) the amplifier has no direct protection. At continuous large currents, the temperature protection will take over.

4. Power supply voltage is wrongly connected or low (for correct voltage see underside of PJ 12)

The protection mode will do the following things:

1. Disconnect the amplifier output.
2. Disconnect the amplifier input.
3. Reset the bias current to 0 mA.

The protection mode can only be deactivated by switching the amplifier off with the Mains Switch (6.) and leave it off for at least 30 seconds.

If the amplifier is switched on again within those 30 seconds the protection mode will automatically be activated.

*Note:* This also happens if the amplifier worked properly before switching it off!

### Cables

Always use loudspeaker and audio cables and connectors of the highest quality.

Siltech cable is used throughout internally and we recommend using this same cable for all external connections.

If you have the choice between longer loudspeaker cables or longer audio cables, choose the latter (cables between pre-amp and power amp will cause the least signal quality loss).

## 7. USING THE AMP WITHOUT PROTECTION CIRCUIT

To adjust the internal controls of the Project Twelve the protection circuit board may be removed. This ensures that all adjustment points on the main board are freely visible and accessible (instead of through small openings in the protection circuit board).



### WARNING!

The amplifier may be used without the protection circuit. We do not recommend this however while this prevents the output from being disconnected in case of any malfunction.

**SPHINX is not responsible for any damage caused by the removal of the protection circuit or the use of the amp without the protection circuit!**

### Removing the protection circuit board

The protection circuit board is mounted on top of the upper main printed circuit board of the amplifier. The drawing "Schematic layout of project 12 with securityprint" (page 14) shows the main board of the Project Twelve with the protection circuit including all the parts mentioned below. Use the following steps:

1. Remove the top cover plate of the amp. It is fixed with one hex screw (M4x12) at the rear panel
2. Remove the two small screws (M3x6) of the protection circuit board.
3. Unsolder the five wires at the top-left corner (Audio-IN).
4. Unsolder the two PTC-resistors (for the over-temperature protection at 70 °C).
5. Carefully remove the circuit board (there is only one way of doing this due to the mounted Balanced/Unbalanced switch):
  - a) Lift up the front side of the board so the large connector is disconnected from the main circuit board.
  - b) Lift the rear side of the board to disconnect the other connector.Now you may remove the board.
6. Connect the input signal to the main circuit board with the special Servicing Cable (\*).
7. Reposition the jumper from JP2 & JP3 to JP1 & JP2.  
The output relay now works without control signal from the protection circuit.

### Repositioning the protection circuit board

To reposition the protection circuit board you use the steps from the previous "Removing the..."-procedure but in reverse order.

1. Reposition the jumper from JP1 & JP2 to JP2 & JP3.  
If not, the protection circuit will not be able to disconnect the amplifier's output.
2. Position the board over the mounting positions and stick the Balanced/Unbalanced button through the appropriate opening in the rear panel of the housing.
3. Carefully insert the rear connector into the corresponding main circuit board socket and then the front connector in it's socket.

### Attention:

Incorrectly positioned connectors may cause damage to the Project Twelve and the pre-amp.

4. Fix the protection circuit board position with the two small screws.
5. Solder the five wires to their correct positions (position #1 is the one at the rear, see also the drawing):
  - 1) Red (+) wire from BALANCED IN
  - 2) Red (+) wire from UNBALANCED IN
  - 3) Black wire (ground) from BALANCED IN
  - 4) Black wire (ground) from UNBALANCED IN
  - 5) Blue (-) wire from BALANCED IN.
6. Solder the two PTC-resistors to the circuit board.
7. Replace the top cover plate of the housing and fix it with the hex screw.

(\*) If there is no Servicing Cable available you may make one yourself using a suitable connector. Connect the wires as follows:

- Pin 1 (and 2) = negative signal: connect to blue wire from Balanced In
- Pin 3 (and 4) = ground: connect to black wire of both inputs
- Pin 5 (and 6) = positive signal: connect to red wire of both inputs

The 6 pin connector at the main board then can be used as the signal input.



## 8. ADJUSTMENT PROCEDURES

The Project Twelve has three adjustable settings:

1. **Bias:** to set the bias current of the power-FETs
2. **Offset:** to set the minimal DC voltage for the output
3. **Common Mode:** to maximise the common mode rejection of the balanced input

Re-adjustment of one or more might be necessary due to ageing or when parts have been replaced or repaired.

**Attention:**

When re-adjusting any setting please ensure that there is no loudspeaker connected to the output! Otherwise the loudspeaker may be seriously damaged.

**Attention:**

The amplifier is able to generate high output voltages of over + or -60 V.

Please be very careful during the adjustments!

After removing the top cover plate you will see the three main sections of the amplifier:

1. The power transformer
2. The main printed circuit board holding the actual audio amplifier
3. The protection circuit board responsible for switching the Project Twelve on and off.

### Bias

With this procedure you set the proper bias level for the power FETs. This ensures their Class A operation at low power levels.

Connect the amplifier according to the drawing "connection diagram for testing the project 12" (page 13).

The input of the amplifier must be shorted (by way of the MUTE function of the oscillator).

- Switch the amplifier ON and wait until it has reached the proper working temperature (this takes an hour).
- Set the millivolt-meter to the DC-range.
- Place the two measuring clips of the meter across one of the source resistors (R30, R31, R39, R40, R43 or R45: see schematic at page 15).
- The level should be 10 mV DC ( $\pm 2$  mV).  
If not: adjust potmeter P2 until the level is 10 mV (P2 can be reached via the 'bias' adjustment hole in the protection circuit board).

**Attention:**

All source resistors must show the same 10 mV value. If not this indicates that the FETs are not accurately matched and their variance is too high. This will cause offset- and bias-problems which can be detected with a THD analyser as a very specific type of distortion.

In that case you should replace the FET sextuplet with a new one (3 matched ones and their inverse counterparts): they can be ordered from SPHINX.

- Switch the oscillator on and set it to 1 kHz and a level of 0 dBu.
- Check the distortion with a THD analyser: it should conform the specified values (0.006% IHF-A @ 1 kHz).
- If this is correct the procedure is finished.
- You may now switch off the amplifier or continue with another adjustment procedure.

## Offset

The Offset adjustment procedure minimises the DC offset value of the amplifier output. This DC offset is important when capacitive loads are used, such as electrostatic loudspeakers. These loudspeakers often use a very low-impedance step-up transformer. The amplifier 'sees' this load as a short for the DC voltage.

Connect the amplifier according to the drawing "Connection diagram for testing the project 12" (page 13).

The input of the amplifier must be shorted (by way of the MUTE function of the oscillator).

### Attention:

Be careful not to trip the offset protection mode. It will activate when the output DC offset exceeds +/- 350 mV.

This mode can only be reset by switching off the amplifier with the Mains switch (6.) and switching it on again after a waiting period of at least 30 seconds.

Please be careful during the adjustments!

- Switch the amplifier ON and wait until it has reached the proper working temperature (this takes an hour).
- Set the millivolt-meter to the DC-range.
- Place the measurement clips of the meter over the output terminal.
- The level should not exceed +5 or -5 mV DC. If not: adjust potmeter P1 until the level is within this range (P1 can be reached via the 'offset' adjustment hole in the protection circuit board).
- Switch the oscillator on and set it to 1 kHz and a level of 0 dBu.
- Check the distortion with a THD analyser: it should be conform the specified values (0.006% IHF-A @ 1 kHz).
- If this is correct the procedure is finished.
- You may now switch off the amplifier or continue with another adjustment procedure.

## Common mode

The Common mode adjustment procedure minimises the amplification error of the (internal) differential amplifier.

If the balanced input amplifier receives an identical signal at the normal (+) and inverted (-) input the output signal will be zero. This helps to reduce the effect of external noise signals while these will be induced at the same level in both signal conductors.

The Common Mode adjustment is optimally set during manufacturing (the error is as low as possible).

Connect the amplifier according to the drawing "Connection diagram for testing the project 12" (page 13, except with both + and - input connected to each other, and use the special input connector. This connector supplies both the plus (+) and minus (-) input pins of the XLR with the same signal.

The 'balanced/unbalanced'-switch on the rear panel **must** be set to 'balanced'.

If there is no signal analyser available you may use an oscilloscope at the output to view the waveform.

- Switch the amplifier ON and wait until it has reached the proper working temperature (this takes an hour).
- Switch the oscillator on and set it to 1 kHz and a level of 0 dBu.
- Adjust potmeter P3 until the minimum level is set (P3 can be reached via the 'bal.' adjustment hole in the protection circuit board). When using a phase analyser the minimum point is reached when the output phase reverses 180° re. the input.
- Also check the setting at 10 Hz, 100 Hz and 10 kHz. Readjust when necessary.
- If the common mode is at minimum level at all frequencies the adjustment is completed.
- You may now switch off the amplifier or continue with another adjustment procedure.

## 9. PROBLEMS AND SOLUTIONS

At the moment of writing the Project Twelve has one known specific problem. If in the future you encounter any problem(s) you may enter the info in this table. This table can then be used for future reference.

Please also send (by fax or e-mail) the specific information to the **Sphinx International Service Department** (see page 3): this info can then be added to the general database to aid others.

Problem	Cause	Solution	Refer to page...
Protection is not functioning properly,	Jumpercap is on JP1&JP2, Amplifier is in 'test'-mode	Place jumpercap on JP2&JP3	15
Cannot adjust common mode properly,	Capacitor C2 is short-circuited,	Replace capacitor C2	16

## 10. DIAGRAMS AND PARTS LISTS

The next pages contain a complete set of schematic drawings including the associated parts lists (if applicable).

Connection diagram for testing the project 12 .....	13
Schematic layout of project 12 with securityprint .....	14
Schematic layout of all relevant parts .....	15
Project 12 amplifier diagram .....	16
Project 12 protection diagram .....	17
PCB drawings of Project 12 .....	18
Partlist amplifier .....	19
Partlist protection .....	22

# SPHINX Project Twelve Service Manual

## Connection diagram for testing the project 12

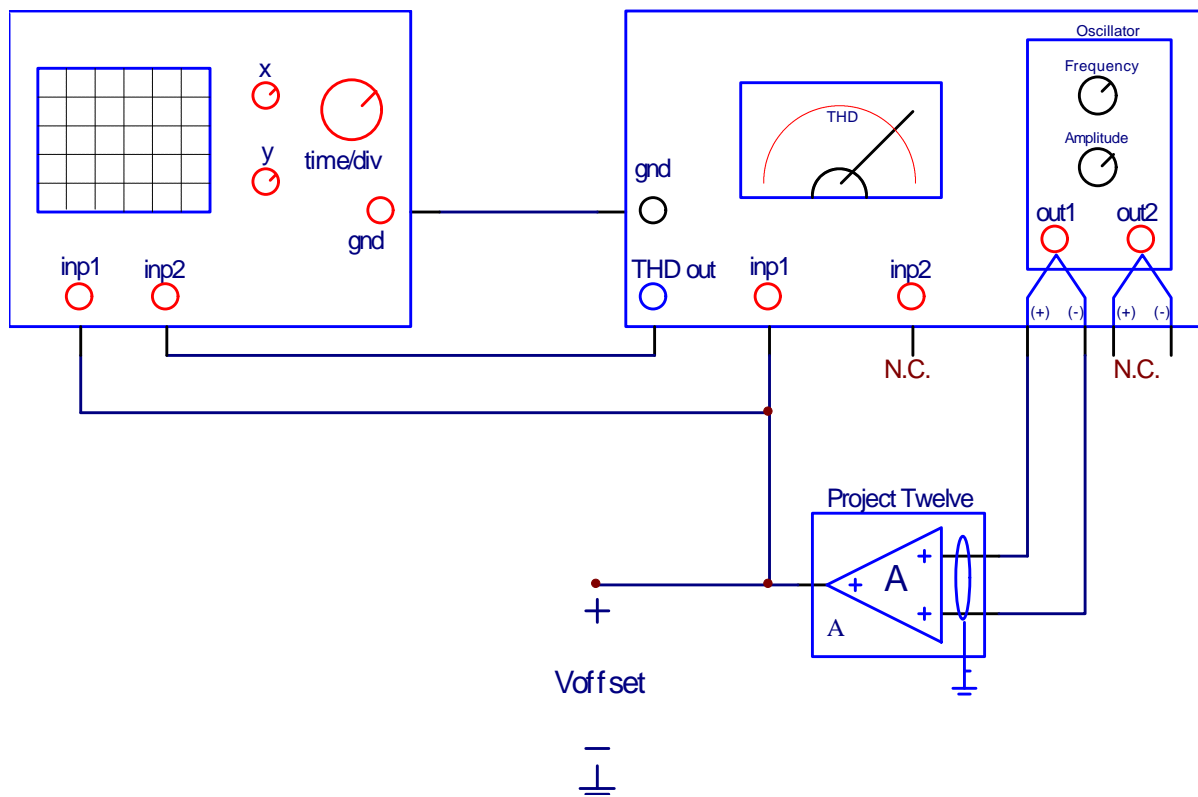

# SPHINX Project Twelve Service Manual

## Schematic layout of project 12 with securityprint

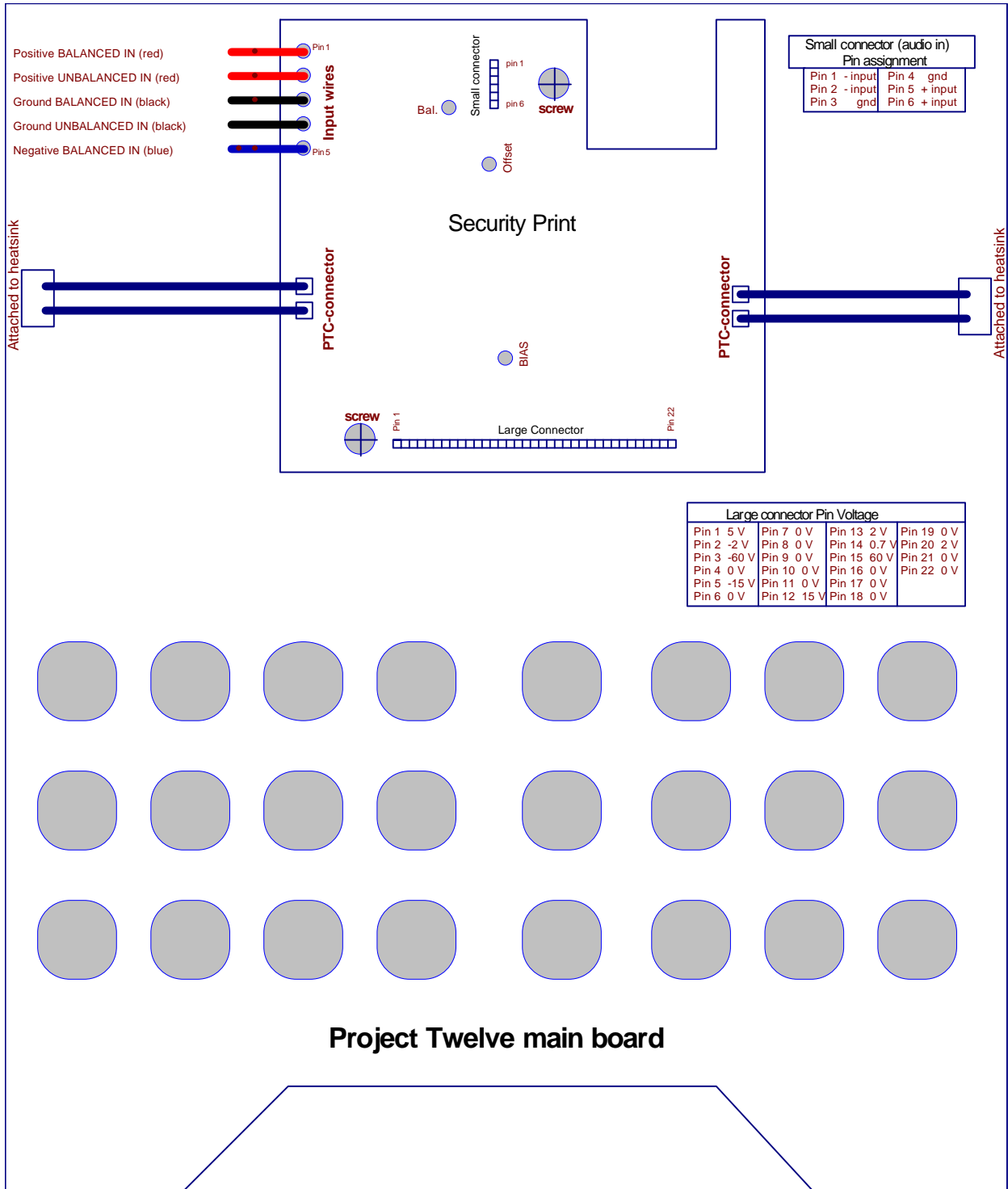

## Schematic layout of all relevant parts

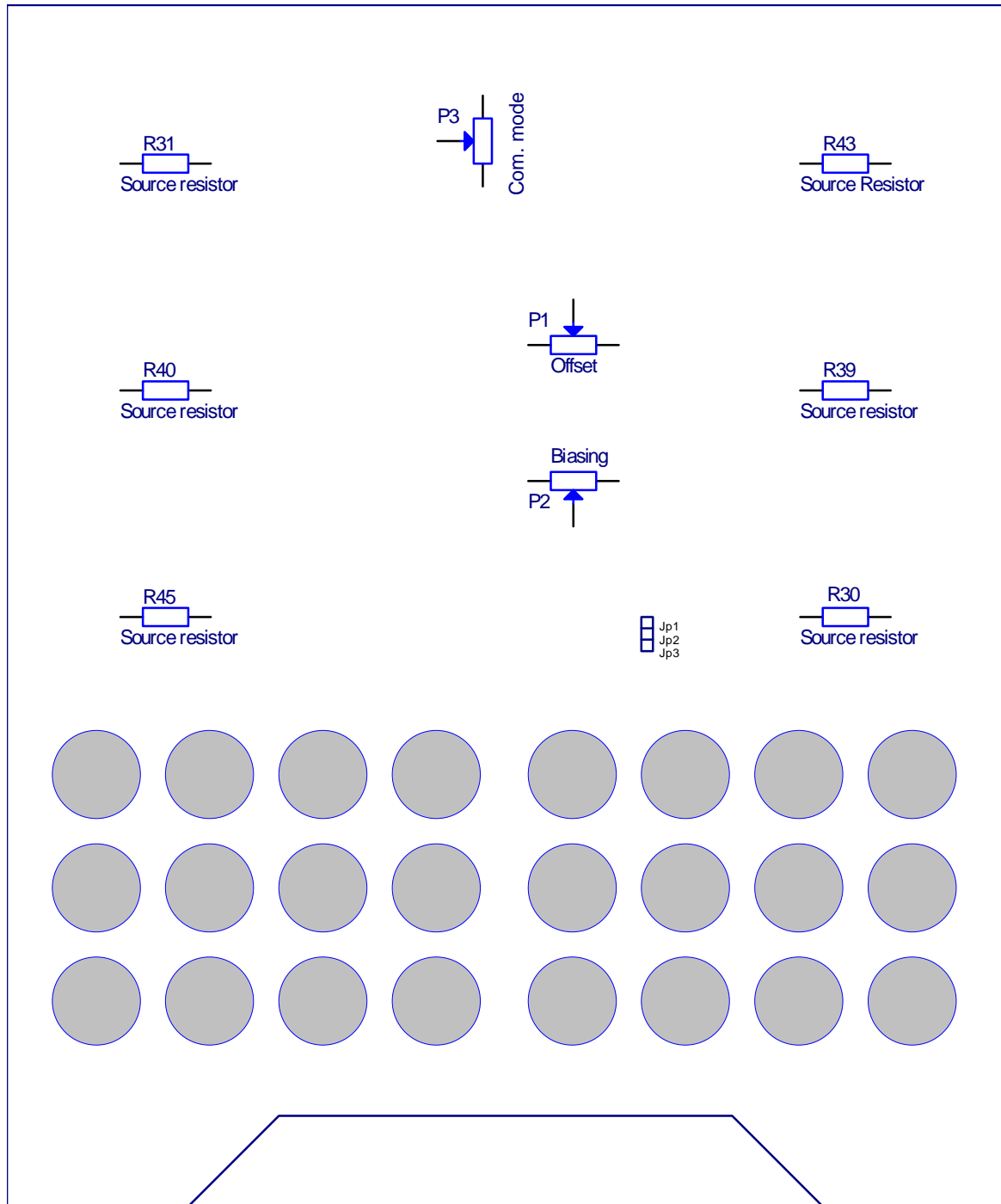

# SPHINX Project Twelve Service Manual

## Project 12 amplifier diagram

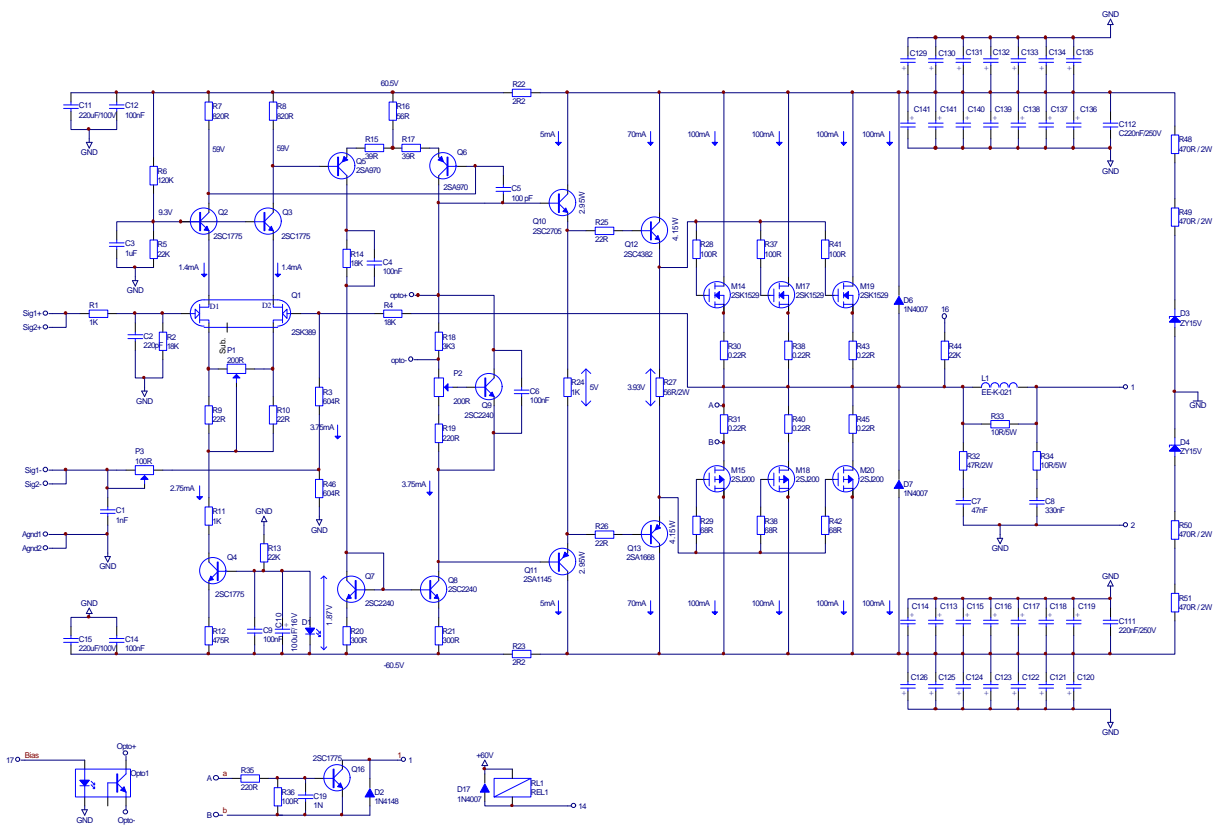



# SPHINX Project Twelve Service Manual

## Project 12 protection diagram

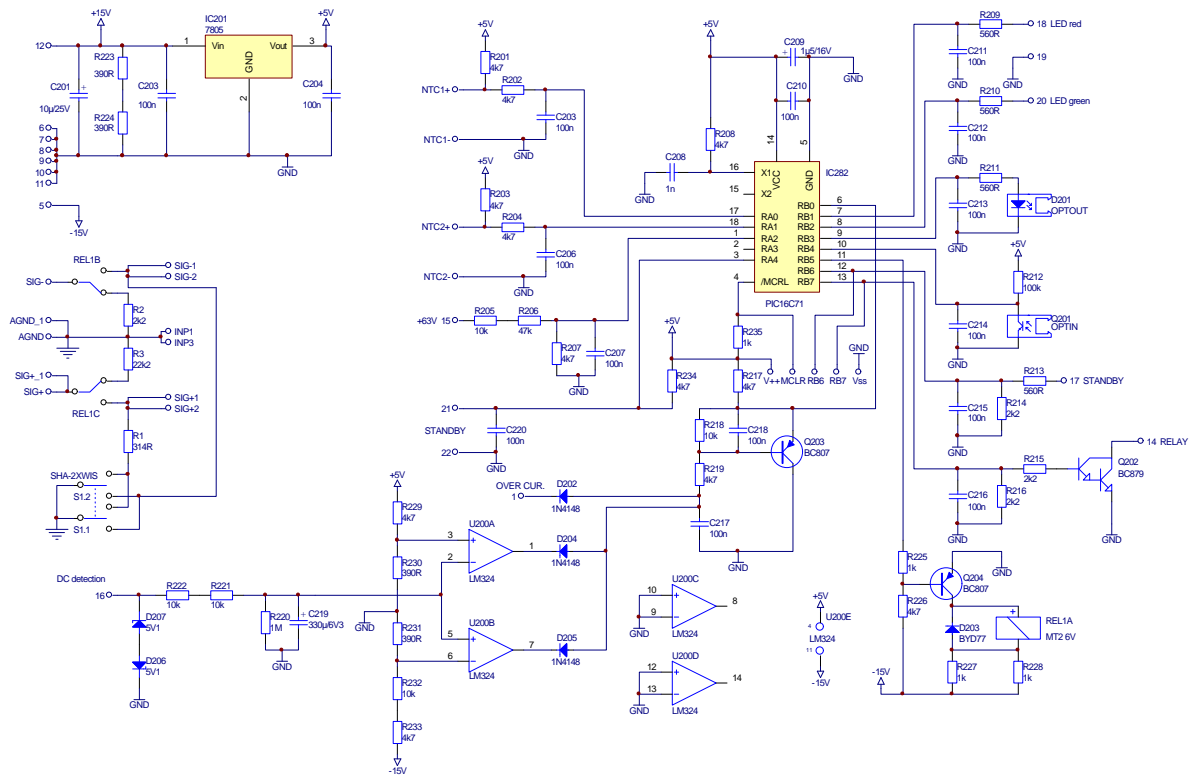

## **PCB drawings of Project 12**

Because there is a significant image-quality loss during the conversion of the drawings, the PCB-drawings are located in separate files.

These files are in PDF-format (Adobe Acrobat 3.0 Reader).

- Pj12Main.PDF for Mainboard
- Pj12Protect.PDF for Protectionboard

## Partlist amplifier

Designator	Part Type	Description
C1	1nF	Capacitor
C10	100uF/16V	Capacitor
C11	220uF/100V	Capacitor
C111	220nF/250V	Capacitor
C112	C220nF/250V	Capacitor
C113	1000uF/100V	Capacitor
C114	1000uF/100V	Capacitor
C115	1000uF/100V	Capacitor
C116	1000uF/100V	Capacitor
C117	1000uF/100V	Capacitor
C118	1000uF/100V	Capacitor
C119	1000uF/100V	Capacitor
C12	100nF	Capacitor
C120	1000uF/100V	Capacitor
C121	1000uF/100V	Capacitor
C122	1000uF/100V	Capacitor
C123	1000uF/100V	Capacitor
C124	1000uF/100V	Capacitor
C125	1000uF/100V	Capacitor
C126	1000uF/100V	Capacitor
C129	1000uF/100V	Capacitor
C130	1000uF/100V	Capacitor
C131	1000uF/100V	Capacitor
C132	1000uF/100V	Capacitor
C133	1000uF/100V	Capacitor
C134	1000uF/100V	Capacitor
C135	1000uF/100V	Capacitor
C136	1000uF/100V	Capacitor
C137	1000uF/100V	Capacitor
C138	1000uF/100V	Capacitor
C139	1000uF/100V	Capacitor
C14	100nF	Capacitor
C140	1000uF/100V	Capacitor
C141	1000uF/100V	Capacitor
C141	1000uF/100V	Capacitor
C15	220uF/100V	Capacitor
C19	1N	Capacitor
C2	220pF	Capacitor
C3	1uF	Capacitor
C4	100nF	Capacitor
C5	100 pF	Capacitor Styroflex
C6	100nF	Capacitor
C7	47nF	Capacitor
C8	330nF	Capacitor
C9	100nF	Capacitor
D1	LED	LED
D17	1N4007	Diode
D2	1N4148	Diode
D3	ZY15V	Zener diode
D4	ZY15V	Zener diode
D6	1N4007	Diode
D7	1N4007	Diode

# SPHINX Project Twelve Service Manual

Designator	Part Type	Description
L1	EE-K-021	Coil
M14	2SK1529	Transistor
M15	2SJ200	Transistor
M17	2SK1529	Transistor
M18	2SJ200	Transistor
M19	2SK1529	Transistor
M20	2SJ200	Transistor
Opto1	OPTO COUPLER	Opto Coupler
P1	200R	Variable resistor
P2	200R	Variable resistor
P3	100R	Variable resistor
Q1	2SK389	Transistor
Q10	2SC2705	Transistor
Q11	2SA1145	Transistor
Q12	2SC4382	Transistor
Q13	2SA1668	Transistor
Q16	2SC1775	Transistor
Q2	2SC1775	Transistor
Q3	2SC1775	Transistor
Q4	2SC1775	Transistor
Q5	2SA970	Transistor
Q6	2SA970	Transistor
Q7	2SC2240	Transistor
Q8	2SC2240	Transistor
Q9	2SC2240	Transistor
R1	1K	Resistor
R10	22R	Resistor
R11	1K	Resistor
R12	475R	Resistor
R13	22K	Resistor
R14	18K	Resistor
R15	39R	Resistor
R16	56R	Resistor
R17	39R	Resistor
R18	3K3	Resistor
R19	220R	Resistor
R2	18K	Resistor
R20	300R	Resistor
R21	300R	Resistor
R22	2R2	Resistor
R23	2R2	Resistor
R24	1K	Resistor
R25	22R	Resistor
R26	22R	Resistor
R27	56R/2W	Resistor 2W
R28	100R	Resistor
R29	68R	Resistor
R3	604R	Resistor
R30	0.22R	Resistor 5W
R31	0.22R	Resistor 5W
R32	47R/2W	Resistor 2W

<b>Designator</b>	<b>Part Type</b>	<b>Description</b>
R33	10R/5W	Resistor 5W
R34	10R/5W	Resistor 5W
R35	220R	Resistor
R36	100R	Resistor
R37	100R	Resistor
R38	0.22R	Resistor 5W
R38	68R	Resistor
R4	18K	Resistor
R40	0.22R	Resistor 5W
R41	100R	Resistor
R42	68R	Resistor
R43	0.22R	Resistor 5W
R44	22K	Resistor
R45	0.22R	Resistor 5W
R46	604R	Resistor
R48	470R / 2W	Resistor 2W
R49	470R / 2W	Resistor 2W
R5	22K	Resistor
R50	470R / 2W	Resistor 2W
R51	470R / 2W	Resistor 2W
R6	120K	Resistor
R7	820R	Resistor
R8	820R	Resistor
R9	22R	Resistor
RL1	REL1	Relay

## Partlist protection

Designator	Part Type	Description
C201	10 $\mu$ /25V	Electrolitic capacitor
C203	100n	MKT capacitor
C203	100n	MKT capacitor
C204	100n	MKT capacitor
C206	100n	MKT capacitor
C207	100n	MKT capacitor
C208	1n	MKT capacitor
C209	1 $\mu$ 5/16V	Electrolitic capacitor
C210	100n	MKT capacitor
C211	100n	MKT capacitor
C212	100n	MKT capacitor
C213	100n	MKT capacitor
C214	100n	MKT capacitor
C215	100n	MKT capacitor
C216	100n	MKT capacitor
C217	100n	MKT capacitor
C218	100n	MKT capacitor
C219	330 $\mu$ /6V3	Electrolitic capacitor
C220	100n	MKT capacitor
D201	OPTOUT	optical output
D202	1N4148	DIODE
D203	BYD77	DIODE
D204	1N4148	DIODE
D205	1N4148	DIODE
D206	5V1	ZENER DIODE
D207	5V1	ZENER DIODE
IC201	LM7805	Voltage regulator
IC282	PIC16C71	Microcontroller
Q201	OPTIN	optical output
Q202	BC879	Transistor
Q203	BC807	Transistor
Q204	BC807	Transistor
R1	314R	Resistor
R2	2k2	Resistor
R201	4k7	Resistor
R202	4k7	Resistor
R203	4k7	Resistor
R204	4k7	Resistor
R205	10k	Resistor
R206	47k	Resistor
R207	4k7	Resistor
R208	4k7	Resistor
R209	560R	Resistor
R210	560R	Resistor

# SPHINX Project Twelve Service Manual

Designator	Part Type	Description
R211	560R	Resistor
R212	100k	Resistor
R213	560R	Resistor
R214	2k2	Resistor
R215	2k2	Resistor
R216	2k2	Resistor
R217	4k7	Resistor
R218	10k	Resistor
R219	4k7	Resistor
R220	1M	Resistor
R221	10k	Resistor
R222	10k	Resistor
R223	390R	Resistor
R224	390R	Resistor
R225	1k	Resistor
R226	4k7	Resistor
R227	1k	Resistor
R228	1k	Resistor
R229	4k7	Resistor
R230	390R	Resistor
R231	390R	Resistor
R232	10k	Resistor
R233	4k7	Resistor
R234	4k7	Resistor
R235	1k	Resistor
R3	22k2	Resistor
REL1	MT2 6V	Relay
S1	SHA-2XWIS	Switch
U200	LM324	Quad OPAMP

©1998 Audioscript BV

Version: 3-09-1998