

SERVICE MANUAL

MYTH 3

INTEGRATED STEREO AMPLIFIER

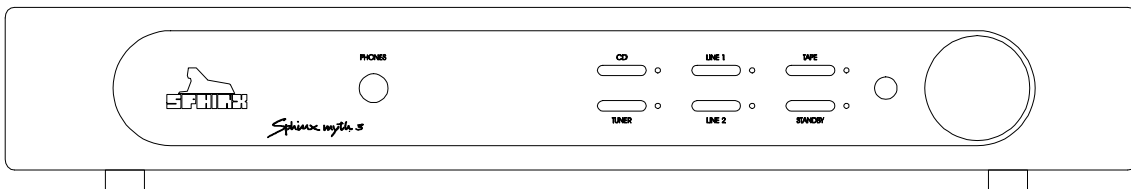

1. UNPACKING3

2. CONTACTING THE MANUFACTURER.....3

3. THE AMP AT A GLANCE4

 Front panel..... 4

 Rear panel 5

4. OPERATION6

 Power on..... 6

 Selecting an input 6

 Tape button..... 6

 Adjusting the volume..... 6

 Standby button..... 6

 Power off..... 6

 Amplifier switches to Protection Mode... 6

5. SPHINX REMOTE CONTROL7

 Buttons..... 7

 Operation 8

 Selecting without switching 8

 Batteries..... 8

 Encountering problems... 8

6. TECHNICAL SPECIFICATIONS.....9

7. ADJUSTMENT PROCEDURES.....10

 Bias..... 10

 Offset 10

8. PROBLEMS AND SOLUTIONS11

9. DIAGRAMS AND PARTS LISTS.....12

 Measurement Set-up 13

 General Overview Myth 3..... 14

 Schematic Diagram Power Supply..... 15

 Schematic Diagram Input / Output 16

 Schematic Diagram Amplifier Left..... 17

 Schematic Diagram Amplifier Left..... 18

 Schematic Diagram keyboard 19

 Schematic Diagram control 20

 Parts List 21

The Sphinx Myth 3 design

This service manual will help you to optimally service and repair the Sphinx Myth 3 Integrated Stereo Amplifier

This integrated high-end stereo amplifier is of discrete design throughout (no IC's are used). The Myth 3 uses a passive pre-amp.

The power amp uses specially selected power FETs with a power bandwidth of over 20 MHz, a very fast slew rate and an unsurpassed phase linearity over the power bandwidth.

Each channel uses two 120W/10A FETs and operates as a pure 'current source' with a very low impedance. The amplifiers are therefore very stable and can effortlessly drive every type and format of loudspeaker at maximum quality (even the most complex ones, such as electrostatic and magnetostatic...).

The amp outputs are sent to the loudspeaker connectors via heavy duty, completely gold-plated relays.

To obtain the maximum quality from this integrated amp it is necessary to use it with top quality audio components, preferably with other Sphinx components.

Please also refer to the User Manual of the Myth 3 for information about functions not described in this manual. It is important to familiarise yourself with the special functions, operation and possibilities of the Sphinx Myth 3.

1. UNPACKING

Before leaving the factory every Myth 3 is subjected to stringent and extensive technical and exterior quality inspection.

This ensures you will enjoy many years of high quality audio from a perfect-looking product.

After unpacking your Myth 3 we therefore recommend you carefully check it for any transport damage.

In case of damage: please contact your Sphinx dealer immediately and retain all packing materials for possible proof of damage and possible claims.

Even if the component is in perfect condition you should still keep the packing materials. If you need to transport your Myth 3 at a later time it will be best protected by the original packing materials.

2. CONTACTING THE MANUFACTURER

In case of any problem not covered in this manual or if you have other questions you may contact the **Sphinx International Service Department** in The Netherlands (local time: GMT +1h) during office hours at the following numbers:

Phone: (+31) 35 602 0302
Fax: (+31) 35 602 2806
E-mail: audionl@euronet.nl

It is always very helpful and efficient if you have all relevant information about the specific product and the problem ready.

3. THE AMP AT A GLANCE

Front panel

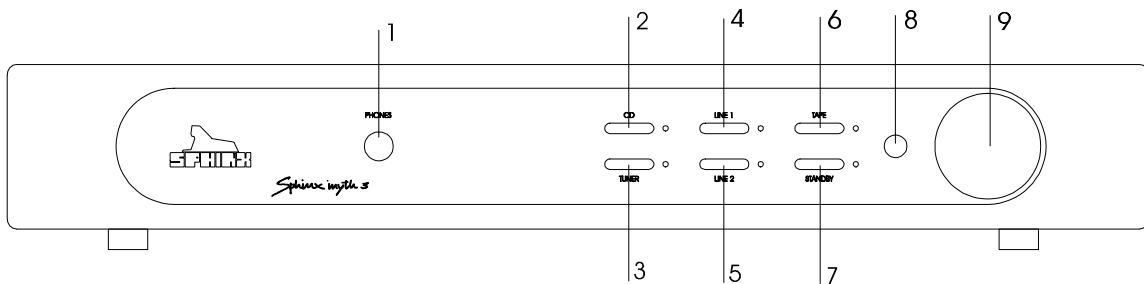

1. **PHONES:** To connect dynamic stereo headphones.
2. **CD:** To select the CD input.
3. **TUNER:** To select the TUNER input.
4. **LINE 1:** To select the LINE 1 input.
5. **LINE 2:** To select the LINE 2 input.
6. **TAPE:** To select the TAPE IN input.
As soon as you have pressed one of the buttons 2. to 6. the corresponding red LED next to it will light.
7. **STANDBY:** To switch the component on and off.
When the component is 'off' (standby) this is indicated by the red LED.
8. **Sensor window** for the IR signal from the Remote Control.
9. **VOLUME:** With this motor-controlled knob you may adjust the volume of the loudspeakers.
The volume can be controlled manually or via the Remote Control.

Rear panel

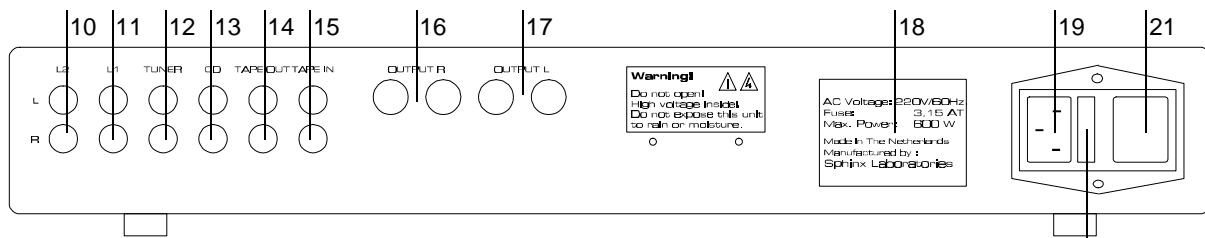

10. **LINE 2:** To connect the cinch signal cable from the signal source for LINE 2.
11. **LINE 1:** To connect the cinch signal cable from the signal source for LINE 1.
12. **TUNER:** To connect the cinch signal cable from the tuner.
13. **CD:** To connect the cinch signal cable from the CD player.
14. **TAPE OUT:** Connect this output to the Input of the recorder.
15. **TAPE IN:** Connect this input to the output of the recorder.
16. **RIGHT OUTPUT:** To connect the cable from the right loudspeaker:
red +
black -
17. **LEFT OUTPUT:** To connect the cable from the left loudspeaker:
red +
black -
18. **Manufacturer's label:** This shows important data for the component, such as serial number and mains power voltage.
19. **AC Power:** Connect the mains cable to a mains power outlet (100 - 240 VAC).
20. **Fuse holder:** Contains a 3.15 A slow type fuse.
21. **ON/OFF:** This is the mains power switch.

4. OPERATION

Once you have finished connecting all components, you can switch on the Myth 3.

Connect the mains cable to a mains outlet. Turn the volume control to 'off' (fully counter-clockwise).

Power on

Switch the Myth 3 on with the ON/OFF switch (21) on the rear panel. The red LED next to the STANDBY button will blink. After a few seconds the CD input is selected: the red LED next to CD (2) will light.

The Myth 3 is now switched on and ready for use.

You can leave the amp on. That way all circuits will remain at optimum operating temperature and the audio quality will be 100% immediately after switching on. Additionally it significantly increases the life span of the component. Only if the amp will not be used for a longer period you might switch it off with the ON/OFF switch (21) to save energy.

Selecting an input

Select the input with one of the buttons 2. to 6. As soon as you have selected an input, the red LED next to the button will light.

CD : To select the CD input.

TUNER : To select the TUNER input.

LINE 1 : To select the LINE 1 input.

LINE 2 : To select the LINE 2 input.

Tape button

Pressing the TAPE button in the front panel (6) selects the TAPE IN input. After you press PLAY on the recorder you will hear the recorded signal.

If you record a tape this button lets you compare the input signal (as selected with button 2., 3., 4. or 5) to the signal from the recorder:

IN (LED red) signal from tape
OUT (LED off) signal from selected input

When using a 3-head recorder you can therefore compare the original signal with the actual recorded signal (you'll hear the 'off-tape' signal which might be slightly delayed).

Adjusting the volume

Using the large VOLUME control (9) you can adjust the sound level from the loudspeakers.

This volume control is motor-controlled. If you adjust the volume on the Remote Control the knob will turn automatically. The position of the knob always correctly indicates the set volume.

Standby button

The STANDBY button (7) temporarily mutes the sound from the loudspeakers: the red LED will light. Another press on the button un-mutes the sound, the LED extinguishes.

You may also use this button when you listen on headphones and would like to switch the loudspeakers off. The Mute function has no influence on the signal to the headphones.

This function can also be controlled using the Remote Control.

Power off

Switch the Myth 3 temporarily off (to stand-by) with the STANDBY button (7).

When the Myth 3 will not be used for a longer period, you may switch it off completely with the ON/OFF switch (21).

Amplifier switches to Protection Mode...

Indication: the Standby LED blinks rapidly and the volume control turns automatically to "zero" (fully counter clockwise).

Note: Switch power off with the ON/OFF switch (21) and wait for at least 60 seconds. In the mean time, check all loudspeaker cables for shorted wires! If you find any, remove the short-circuit to insure fault-free connection.

Now switch the power on with the ON/OFF switch. If the amplifier itself is not defective, it will operate normally again after 30 seconds.

5. SPHINX REMOTE CONTROL

This single Sphinx Remote Control allows you to control all functions: not only of the Myth 3, but of all other Sphinx equipment.

Only the following buttons and indications on the Remote apply to the Myth 3 (the others will not function):

Buttons

1. **PRE-AMP:** To select the amp. All buttons pressed hereafter will control only the amp functions.
2. **STANDBY:** Use this red button to switch the loudspeaker outputs of the Myth 3 off (standby).
3. **1 - 4:** To select inputs CD to Line 2 (*Note: 5 to 0 do not function*):
 - 1 CD
 - 2 Tuner
 - 3 Line 1
 - 4 Line 2
4. **TAPE/MONITOR:** Use this button to select the Tape IN input.
5. **+** button: Pressing this button has the same effect as rotating the VOLUME control on the front panel clockwise. You increase the volume.
6. **—** button: Pressing this button has the same effect as rotating the VOLUME control on the front panel anti-clockwise. You decrease the volume.

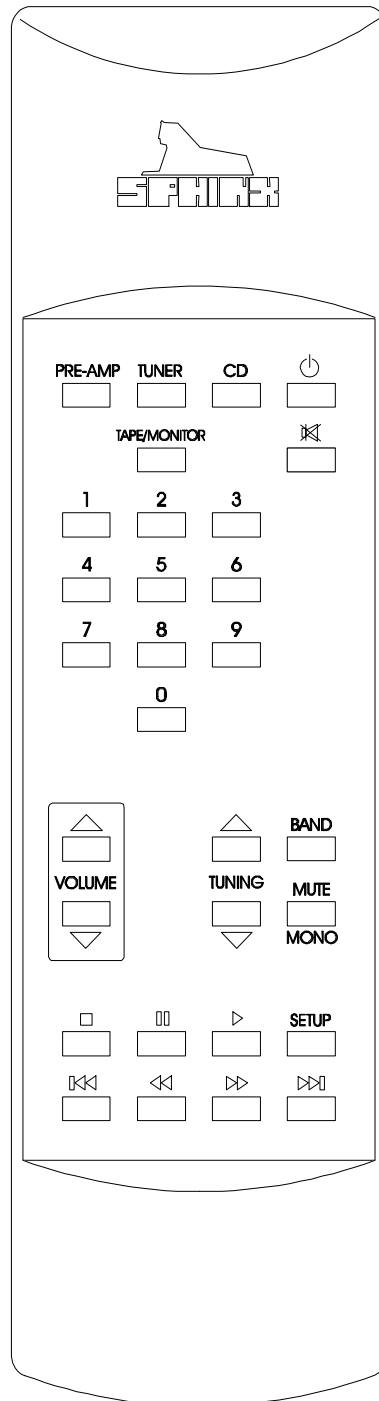

Operation

The Sphinx Remote is used with several different models and can therefore transmit different control codes, depending on which model has been selected with the select buttons (1).

Important: Always press the PRE-AMP button before you send a command (even if you only have one Sphinx component).

Otherwise it is possible that, although the Remote will send a signal, nothing happens because the transmitted signal is not 'recognised' by the component.

Indoors the Remote may be used up to a distance of 7 meter, provided there is no strong sunlight in the room and if you aim the Remote at the component. Always aim the Remote straight at the front panel of the component, the maximum offset angle is 30°.

Selecting without switching

Suppose, for instance, that you would like to select the Tuner to Radio 4 without interrupting CD playback.

In that case you momentarily depress (not longer than 0.5 sec) the 'TUNER' button and the '4' button. The same procedure is used for the other system components.

How to operate the Remote Control with the different Sphinx components will be explained in the corresponding User Manual of each component.

Batteries

The four batteries have a life span of approximately one year during normal use, but shorter when used more intensely.

Replacement batteries: 1.5 V, model *micro* or *penlite* or *LR03* or *AAA* or *AM4* (one of these codes is indicated on the packaging and the batteries). You may also use rechargeable 1.5 V batteries.

Note: Position the new batteries exactly as shown in the illustration at the bottom of the battery compartment, otherwise the Remote will not function!

Encountering problems...

Remote Control does not work	
Wrong component selected	Select the correct one
Distance to component exceeds 7 m	Use Remote at closer range
Angle between Remote and component exceeds $\pm 30^\circ$	Decrease angle
Sensor window on front dirty	Clean window
Batteries empty or incorrectly placed	Use new batteries or replace the old ones correctly
Strong (sun)light in room	Shade off light source
Component is not switched on (!)	Switch it on

Component reacts differently than expected or not at all	
Wrong component selected	Select the correct one
Component or Remote does not function	Check component with its original remote
Batteries in Remote empty	Use new batteries

6. TECHNICAL SPECIFICATIONS

Bandwidth	10 - 103,000 Hz (+0/-3 dB)
Phase response error	<2° (from 0 - 20,000 Hz)
Gain	33 dB max. (44.7 times)
Minimum Power Output (1 - 20.000 Hz)	>2x 50 W into 8 Ω (17.0 dBW), THD <0.01% >2x 68 W into 4 Ω (18.3 dBW), THD <0.02% >2x 66 W into 2 Ω (18.2 dBW), THD <0.01% ³
Output voltage / current, max.	20 V / 10 A
THD+N (IHF-A)	<0.006% (2 nd harm., 10-20,000 Hz)
IMD	<0.030%
S/N ratio (IHF-A)	>100 dB
Channel separation	>70 dB (1 - 20,000 Hz)
Slew rate	>24 V/μs
Damping factor	>525 (1 - 1,000 Hz)
Inputs	
cinch, unbalanced	1x Line 2, 1x Line 1, 1x CD, 1x Tuner, 1x Tape
level, nominal	1.25 V
impedance	20 kΩ
Outputs	
cinch	1x Tape
headphones	1x 6.3 mm stereo jack, adjustable level
clamp	1x loudspeaker L, 1x loudspeaker R
Supply capacitance	18,800 μF total
Power consumption	550 W max. (57.5 W standby)
Dimensions (h x w x d)	110 x 434 x 330 mm
Weight	7 kg

This unit conforms to the EMC interference regulations issued by the EU and to the CE standards.
This unit complies with safety regulation VDE 0860 and therefore with international safety regulation IEC 65.

Technical specifications may be changed by SPHINX without prior notice if technical developments make this necessary.

©1999 Audioscript BV

7. ADJUSTMENT PROCEDURES

The Myth 3 is an integrated amplifier, meaning the pre-amp and power amp sections are combined into one cabinet.

The Myth 3 only has two parameters for each channel (so four in total) that might need adjustment:

- **Bias:** to set the bias current and bias voltage of the amplifier for normal use.
- **Offset:** to set the DC-offset voltage of the output.

These adjustments might be necessary when the amplifier has been used for a period of time (and settings have changed due to ageing) or when a part of the Myth 3 have been replaced.

Attention:

When re-adjusting any setting please ensure that there is no loudspeaker connected to the output! Otherwise the loudspeaker may be seriously damaged.

Attention:

The amplifier is able to generate high output voltages of over + or -40 V. Please be very careful during the adjustments!

Bias

With this procedure you set the proper bias level for the power FETs. This ensures their Class A operation at low power levels.

Connect the amplifier according to the drawing "Measurement Set-up" (page 13).

The input of the amplifier must be shorted (by way of the MUTE function of the oscillator).

- Switch the amplifier ON and wait until it has reached the proper working temperature
- Set the millivolt-meter to the DC-range.
- Place the two measuring clips of the meter across one of the source resistors
 - Left: R30L, R31L
 - Right: R30R, R31R
 (refer to schematic on page 17/18).
- The level for each should be 8 mV DC (± 2 mV). If not: adjust potmeter P2L (Left) or potmeter P2R (Right) until the level is 8 mV.
- Repeat this procedure after 20 minutes to finalise the adjustment.
- Switch the oscillator on and set it to 1 kHz and a level of 0 dBV (1 V).
- Check the distortion with a THD analyser: it should be conform to the specified value (0.01% IHF-A @ 1 – 20 kHz @ 50 W into 8 ohm). If this is correct the procedure is finished.
- You may now switch off the amplifier or continue with another adjustment procedure.

Offset

The Offset adjustment procedure minimises the DC offset value of the amplifier output. This DC offset is important when capacitive loads are used, such as electrostatic loudspeakers. These loudspeakers often use a very low-impedance step-up transformer. The amplifier 'sees' this load as a short for the DC voltage.

Connect the amplifier according to the drawing "Measurement Set-up" (page 13).

The input of the amplifier must be shorted (by way of the MUTE function of the oscillator).

- Switch the amplifier ON and wait until it has reached the proper working temperature.
- Set the millivolt-meter to the DC-range.
- Place the measurement clips of the meter over the output terminal.
- The level should not exceed +1 or -1 mV DC. If it does: adjust potmeter P1L (Left) or P1R (Right) until the level is within this range.
- Repeat this procedure after 20 minutes to finalise the adjustment.
- Switch the oscillator on and set it to 1 kHz and a level of 0 dBV (1 V).
- Check the distortion with a THD analyser: it should be conform to the specified value (0.01% IHF-A @ 1 – 20 kHz @ 50 W into 8 ohm). If this is correct the procedure is finished.
- You may now switch off the amplifier or continue with another adjustment procedure.

9. DIAGRAMS AND PARTS LISTS

The next pages contain the front and rear panel layout and a complete set of schematic drawings including the associated parts lists (if applicable).

Measurement Set-up

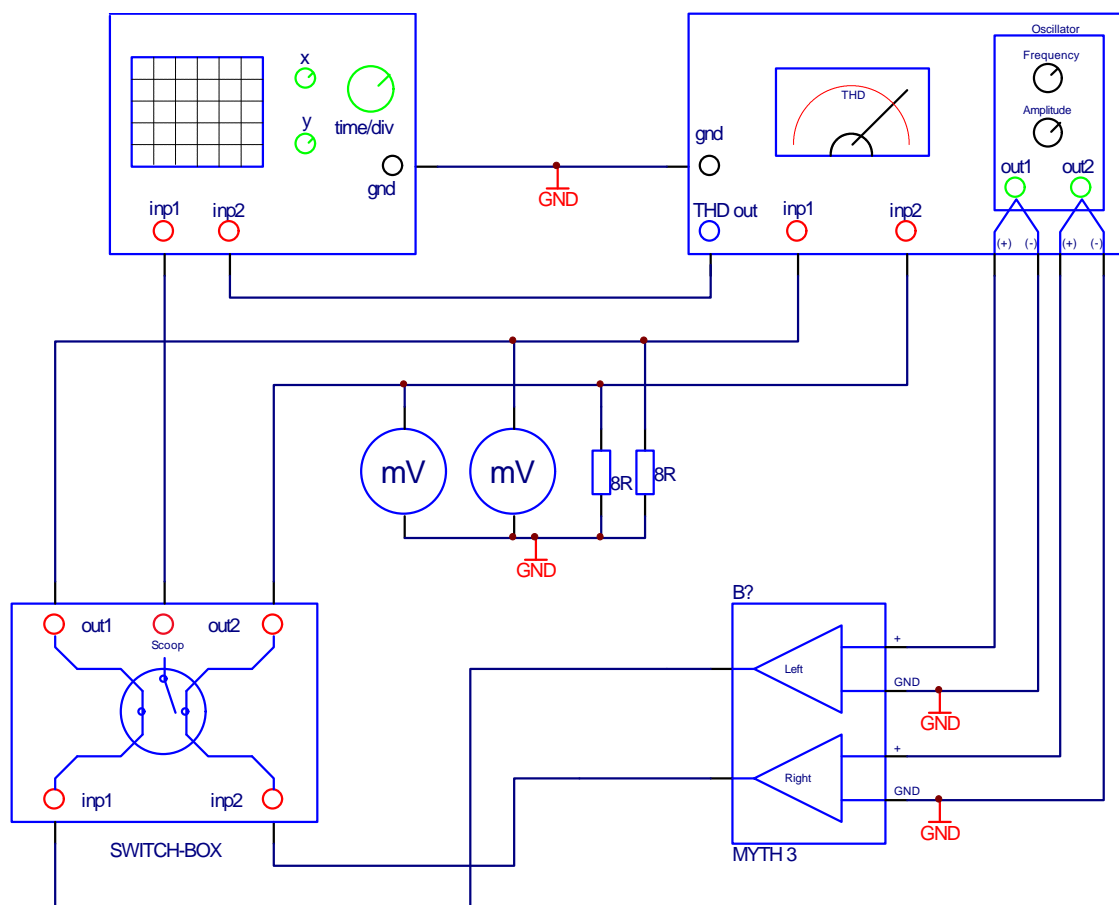



Myth 3 power supply
M3-ps.sch



Myth 3 keyboard
m3-keyb.sch



Myth 3 control
m3-ctrl.sch



Schematic Diagram Power Supply

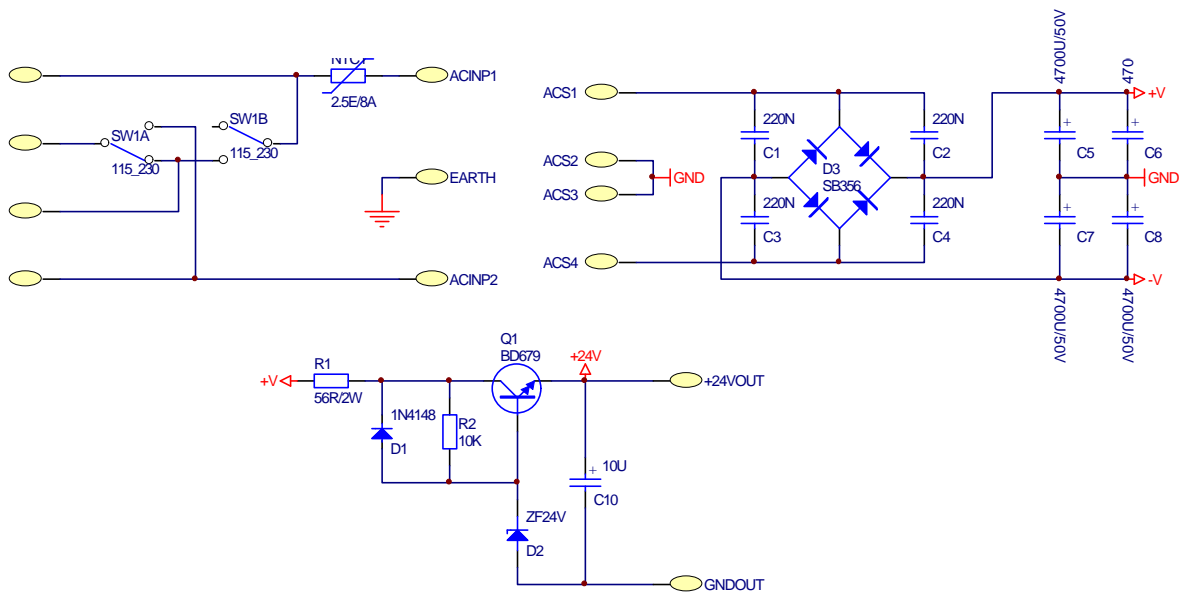

Schematic Diagram Input / Output

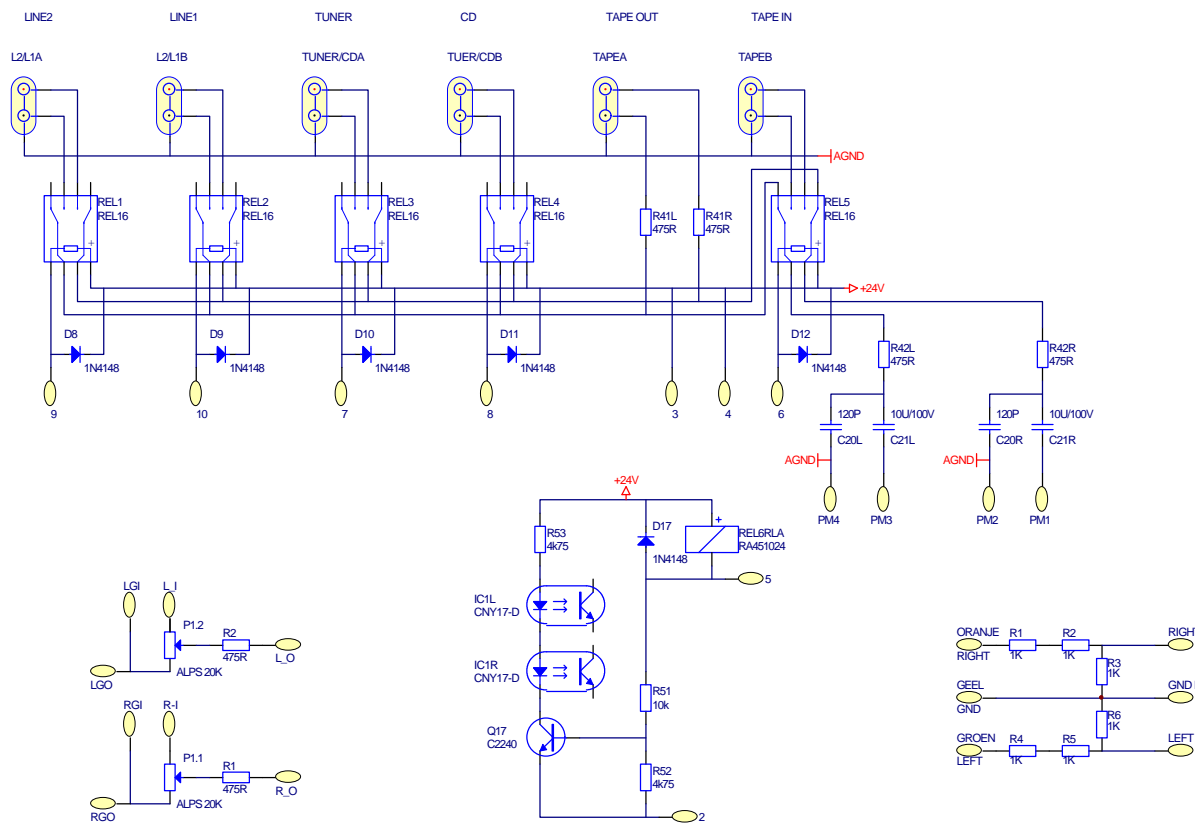

Schematic Diagram Amplifier Left

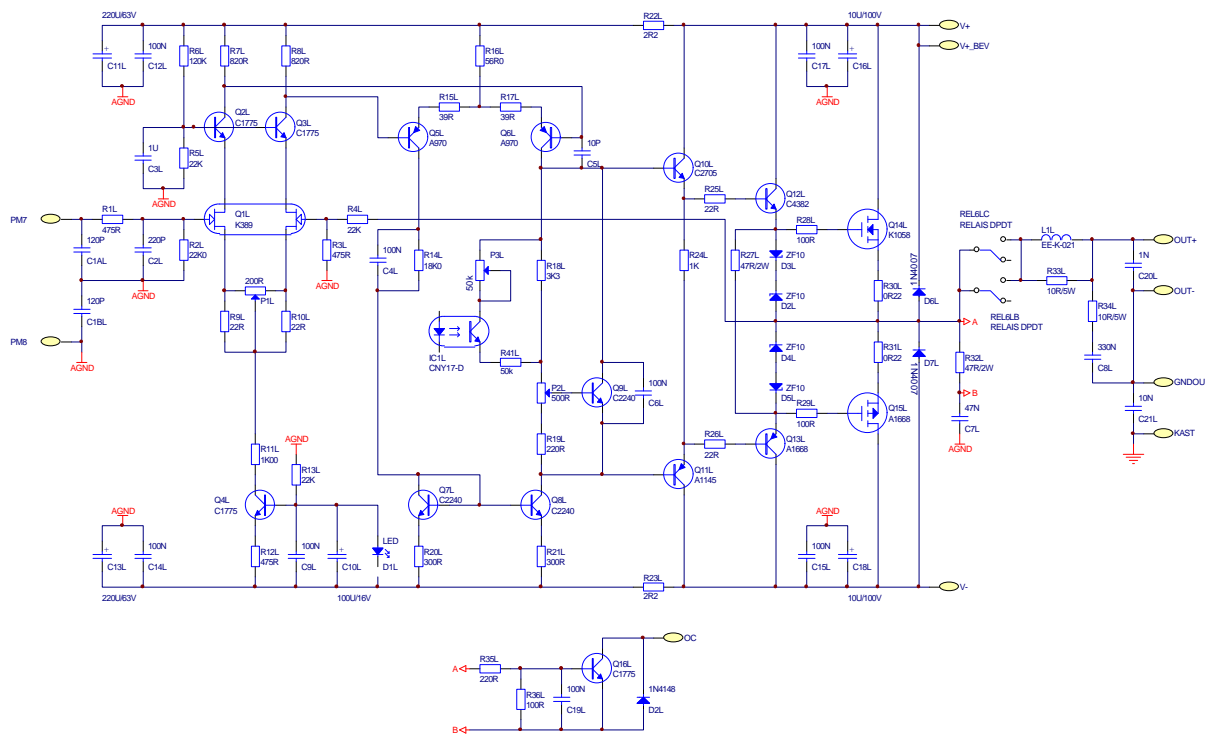

Schematic Diagram Amplifier Right

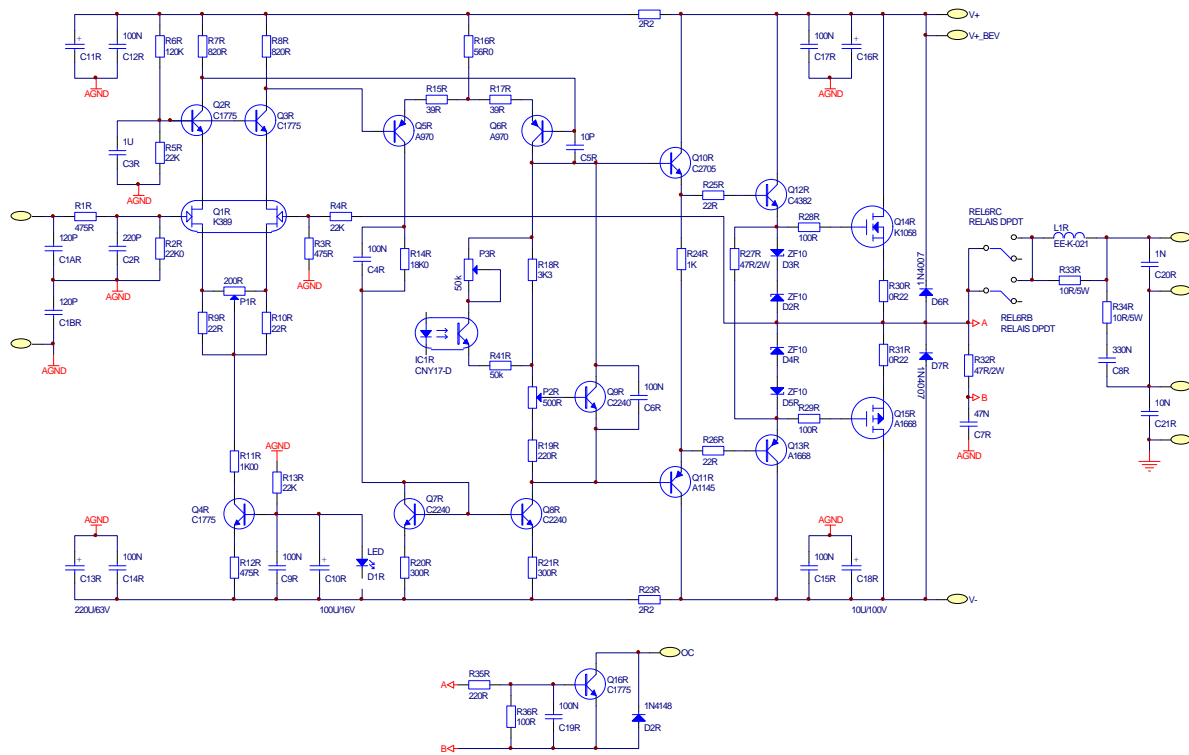

Schematic Diagram keyboard

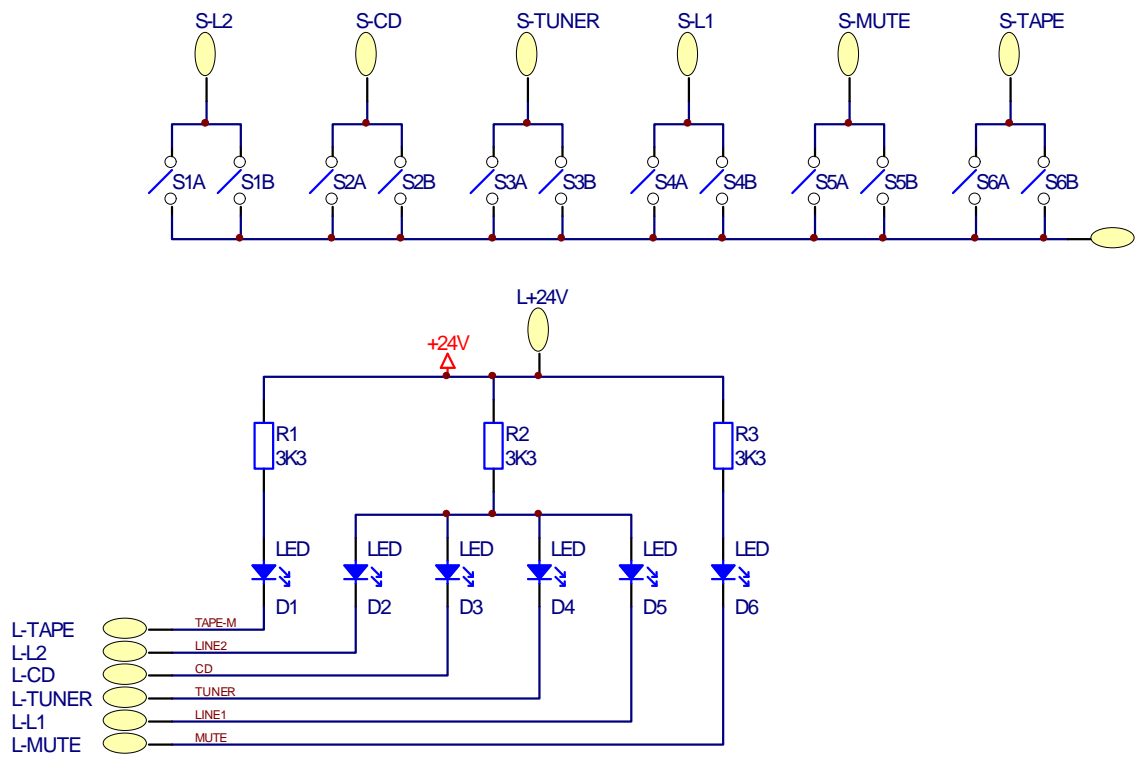

Schematic Diagram control

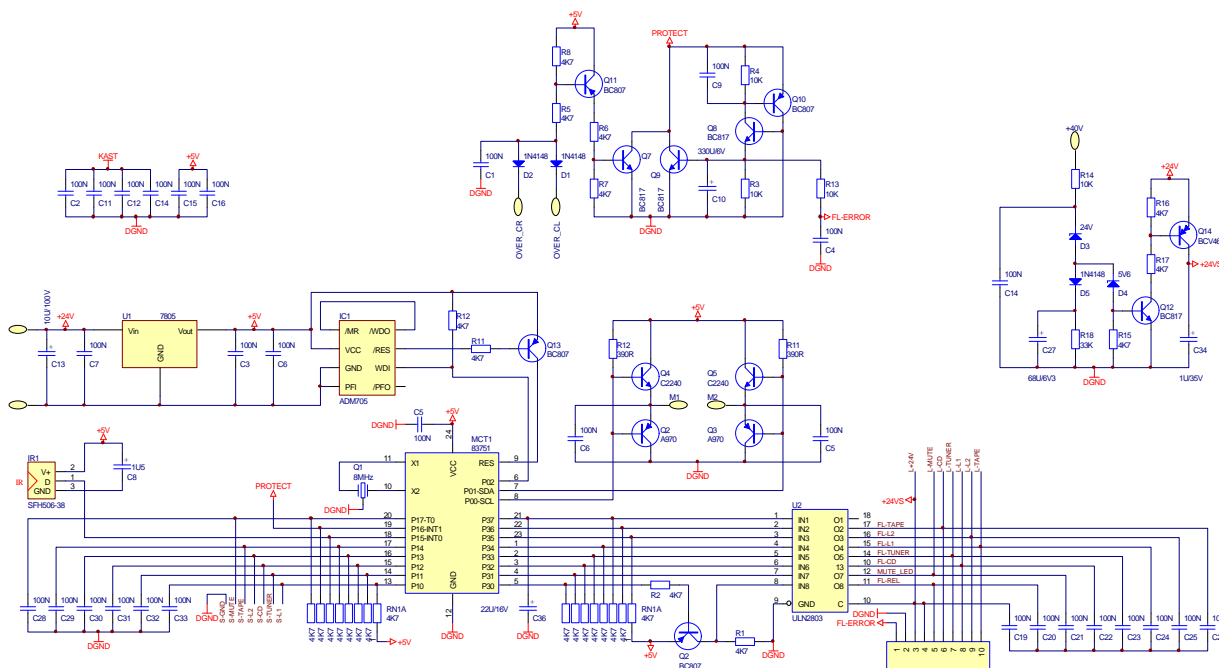

Designator	Part Type	Description
+24VOUT	1PIN	Connector
ACINP1	1PIN	Connector
ACINP2	1PIN	Connector
ACP1	1PIN	Connector
ACP2	1PIN	Connector
ACP3	1PIN	Connector
ACP4	1PIN	Connector
ACS1	1PIN	Connector
ACS2	1PIN	Connector
ACS3	1PIN	Connector
ACS4	1PIN	Connector
C1	100N	MKT capacitor
C1	220N	MKT capacitor
C10	10U	Electrolitic capacitor
C10	330U/6V	Electrolitic capacitor
C10L	100U/16V	Electrolitic capacitor
C10R	100U/16V	Electrolitic capacitor
C11	100N	MKT capacitor
C11L	220U/63V	Electrolitic capacitor
C11R	220U/63V	Electrolitic capacitor
C12	100N	MKT capacitor
C12L	100N	MKT capacitor
C12R	100N	MKT capacitor
C13	10U/100V	Electrolitic capacitor
C13L	220U/63V	Electrolitic capacitor
C13R	220U/63V	Electrolitic capacitor
C14	100N	MKT capacitor
C14	100N	MKT capacitor
C14L	100N	MKT capacitor
C14R	100N	MKT capacitor
C15	100N	MKT capacitor
C15L	100N	MKT capacitor
C15R	100N	MKT capacitor
C16	100N	MKT capacitor
C16L	10U/100V	Electrolitic capacitor
C16R	10U/100V	Electrolitic capacitor
C17L	100N	MKT capacitor
C17R	100N	MKT capacitor
C18L	10U/100V	Electrolitic capacitor
C18R	10U/100V	Electrolitic capacitor
C19	100N	MKT capacitor
C19L	100N	MKT capacitor
C19R	100N	MKT capacitor
C1AL	120P	MKT capacitor
C1AR	120P	MKT capacitor
C1BL	120P	MKT capacitor
C1BR	120P	MKT capacitor
C2	100N	MKT capacitor

Designator	Part Type	Description
C2	220N	MKT capacitor
C20	100N	MKT capacitor
C20L	120P	MKT capacitor
C20L	1N	MKT capacitor
C20R	120P	MKT capacitor
C20R	1N	MKT capacitor
C21	100N	MKT capacitor
C21L	10N	MKT capacitor
C21L	10U/100V	MKT capacitor
C21R	10N	MKT capacitor
C21R	10U/100V	MKT capacitor
C22	100N	MKT capacitor
C23	100N	MKT capacitor
C24	100N	MKT capacitor
C25	100N	MKT capacitor
C26	100N	MKT capacitor
C27	68U/6V3	Electrolitic capacitor
C28	100N	MKT capacitor
C29	100N	MKT capacitor
C2L	220P	MKT capacitor
C2R	220P	MKT capacitor
C3	100N	MKT capacitor
C3	220N	MKT capacitor
C30	100N	MKT capacitor
C31	100N	MKT capacitor
C32	100N	MKT capacitor
C33	100N	MKT capacitor
C34	1U/35V	Electrolitic capacitor
C36	22U/16V	Electrolitic capacitor
C3L	1U	MKT capacitor
C3R	1U	MKT capacitor
C4	100N	MKT capacitor
C4	220N	MKT capacitor
C4L	100N	MKT capacitor
C4R	100N	MKT capacitor
C5	100N	MKT capacitor
C5	100N	MKT capacitor
C5	4700U/50V	Electrolitic capacitor
C5L	10P	MKT capacitor
C5R	10P	MKT capacitor
C6	100N	MKT capacitor
C6	100N	MKT capacitor
C6	4700U/50V	Electrolitic capacitor
C6L	100N	MKT capacitor
C6R	100N	MKT capacitor
C7	100N	MKT capacitor
C7	4700U/50V	Electrolitic capacitor
C7L	47N	MKT capacitor
C7R	47N	MKT capacitor

Designator	Part Type	Description
C8	1U5	Electrolitic capacitor
C8	4700U/50V	Electrolitic capacitor
C8L	330N	MKT capacitor
C8R	330N	MKT capacitor
C9	100N	MKT capacitor
C9L	100N	MKT capacitor
C9R	100N	MKT capacitor
D1	1N4148	Diode
D1	1N4148	Diode
D1	LED	LED
D10	1N4148	Diode
D11	1N4148	Diode
D12	1N4148	Diode
D17	1N4148	Diode
D1L	LED	LED
D1R	LED	LED
D2	1N4148	Diode
D2	LED	LED
D2	ZF24V	Zener diode
D2L	1N4148	Diode
D2L	ZF10	Zener diode
D2R	1N4148	Diode
D2R	ZF10	Zener diode
D3	24V	Zener diode
D3	LED	LED
D3	SB356	Diode
D3L	ZF10	Zener diode
D3R	ZF10	Zener diode
D4	5V6	Zener diode
D4	LED	led
D4L	ZF10	Zener diode
D4R	ZF10	Zener diode
D5	1N4148	Diode
D5	LED	LED
D5L	ZF10	Zener diode
D5R	ZF10	Zener diode
D6	LED	LED
D6L	1N4007	Diode
D6R	1N4007	Diode
D7L	1N4007	Diode
D7R	1N4007	Diode
D8	1N4148	Diode
D9	1N4148	Diode
EARTH	1PIN	Connector
GEEL	GND	Connector
GNDOUT	1PIN	Connector
GROEN	LEFT	Connector
IC1	ADM705	IC
IC1L	CNY17-D	Optocoupler

Designator	Part Type	Description
IC1L	CNY17-D	Optocoupler
IC1R	CNY17-D	Optocoupler
IC1R	CNY17-D	Optocoupler
IR1	SFH506-38	Infrared receiver
L1L	EE-K-021	Coil
L1R	EE-K-021	Coil
L2/L1	CINCH-MYTH4P	Connector
M1	1PIN	Connector
M2	1PIN	Connector
MCT1	83751	
NTC1	2.5E/8A	NTC myth devices
ORANJE	RIGHT	Connector
P1.1	ALPS 20K	Adj. Potmeter
P1.2	ALPS 20K	Adj. Potmeter
P1L	200R	Adj. Potmeter
P1R	200R	Adj. Potmeter
P2L	500R	Adj. Potmeter
P2R	500R	Adj. Potmeter
P3L	50k	Adj. Potmeter
P3R	50k	Adj. Potmeter
Q1	8MHz	XTAL
Q1	BD679	Transistor
Q10	BC807	Transistor
Q10L	C2705	Transistor
Q10R	C2705	Transistor
Q11	BC807	Transistor
Q11L	A1145	Transistor
Q11R	A1145	Transistor
Q12	BC817	Transistor
Q12L	C4382	Transistor
Q12R	C4382	Transistor
Q13	BC807	Transistor
Q13L	A1668	Transistor
Q13R	A1668	Transistor
Q14	BCV46	Transistor
Q14L	K1058	Transistor
Q14R	K1058	Transistor
Q15L	A1668	Transistor
Q15R	A1668	Transistor
Q16L	C1775	Transistor
Q16R	C1775	Transistor
Q17	C2240	Transistor
Q1L	K389	Dual N-JFET
Q1R	K389	Dual N-JFET
Q2	A970	Transistor
Q2	BC807	Transistor
Q2L	C1775	Transistor
Q2R	C1775	Transistor
Q3	A970	Transistor

Designator	Part Type	Description
Q3L	C1775	Transistor
Q3R	C1775	Transistor
Q4	C2240	Transistor
Q4L	C1775	Transistor
Q4R	C1775	Transistor
Q5	C2240	Transistor
Q5L	A970	Transistor
Q5R	A970	Transistor
Q6L	A970	Transistor
Q6R	A970	Transistor
Q7	BC817	Transistor
Q7L	C2240	Transistor
Q7R	C2240	Transistor
Q8	BC817	Transistor
Q8L	C2240	Transistor
Q8R	C2240	Transistor
Q9	BC817	Transistor
Q9L	C2240	Transistor
Q9R	C2240	Transistor
R1	1K	Resistor
R1	3K3	Resistor
R1	475R	Resistor
R1	4K7	Resistor
R1	56R/2W	Resistor
R10L	22R	Resistor
R10R	22R	Resistor
R11	390R	Resistor
R11	4K7	Resistor
R11L	1K00	Resistor
R11R	1K00	Resistor
R12	390R	Resistor
R12	4K7	Resistor
R12L	475R	Resistor
R12R	475R	Resistor
R13	10K	Resistor
R13L	22K	Resistor
R13R	22K	Resistor
R14	10K	Resistor
R14L	18K0	Resistor
R14R	18K0	Resistor
R15	4K7	Resistor
R15L	39R	Resistor
R15R	39R	Resistor
R16	4K7	Resistor
R16L	56R0	Resistor
R16R	56R0	Resistor
R17	4K7	Resistor
R17L	39R	Resistor
R17R	39R	Resistor

Designator	Part Type	Description
R18	33K	Resistor
R18L	3K3	Resistor
R18R	3K3	Resistor
R19L	220R	Resistor
R19R	220R	Resistor
R1L	475R	Resistor
R1R	475R	Resistor
R2	10K	Resistor
R2	1K	Resistor
R2	3K3	Resistor
R2	475R	Resistor
R2	4K7	Resistor
R20L	300R	Resistor
R20R	300R	Resistor
R21L	300R	Resistor
R21R	300R	Resistor
R22L	2R2	Resistor
R22R	2R2	Resistor
R23L	2R2	Resistor
R23R	2R2	Resistor
R24L	1K	Resistor
R24R	1K	Resistor
R25L	22R	Resistor
R25R	22R	Resistor
R26L	22R	Resistor
R26R	22R	Resistor
R27L	47R/2W	Resistor
R27R	47R/2W	Resistor
R28L	100R	Resistor
R28R	100R	Resistor
R29L	100R	Resistor
R29R	100R	Resistor
R2L	22K0	Resistor
R2R	22K0	Resistor
R3	10K	Resistor
R3	1K	Resistor
R3	3K3	Resistor
R30L	0R22	Resistor
R30R	0R22	Resistor
R31L	0R22	Resistor
R31R	0R22	Resistor
R32L	47R/2W	Resistor
R32R	47R/2W	Resistor
R33L	10R/5W	Resistor
R33R	10R/5W	Resistor
R34L	10R/5W	Resistor
R34R	10R/5W	Resistor
R35L	220R	Resistor
R35R	220R	Resistor

Designator	Part Type	Description
R36L	100R	Resistor
R36R	100R	Resistor
R3L	475R	Resistor
R3R	475R	Resistor
R4	10K	Resistor
R4	1K	Resistor
R41L	475R	Resistor
R41L	50k	Resistor
R41R	475R	Resistor
R41R	50k	Resistor
R42L	475R	Resistor
R42R	475R	Resistor
R4L	22K	Resistor
R4R	22K	Resistor
R5	1K	Resistor
R5	4K7	Resistor
R51	10k	Resistor
R52	4k75	Resistor
R53	4k75	Resistor
R5L	22K	Resistor
R5R	22K	Resistor
R6	1K	Resistor
R6	4K7	Resistor
R6L	120K	Resistor
R6R	120K	Resistor
R7	4K7	Resistor
R7L	820R	Resistor
R7R	820R	Resistor
R8	4K7	Resistor
R8L	820R	Resistor
R8R	820R	Resistor
R9L	22R	Resistor
R9R	22R	Resistor
REL1	REL16	Relay
REL2	REL16	Relay
REL3	REL16	Relay
REL4	REL16	Relay
REL5	REL16	Relay
REL6RL	RA451024	Relay
RN1	4K7	R-ARRAY
RN1	4K7	R-ARRAY
S1	SWITCH-DPST	SWITCH-DPST
S2	SWITCH-DPST	SWITCH-DPST
S3	SWITCH-DPST	SWITCH-DPST
S4	SWITCH-DPST	SWITCH-DPST
S5	SWITCH-DPST	SWITCH-DPST
S6	SWITCH-DPST	SWITCH-DPST
SW1	115_230	SWITCH SPDT X 2
TAPE	CINCH-MYTH4P	Connector

Designator	Part Type	Description
TUNER/CD	CINCH-MYTH4P	Connector
U1	7805	IC
U2	ULN2803	ULN2803

©1999 Audioscript BV

Version: 1999-03-10 22:14